

SG 2195

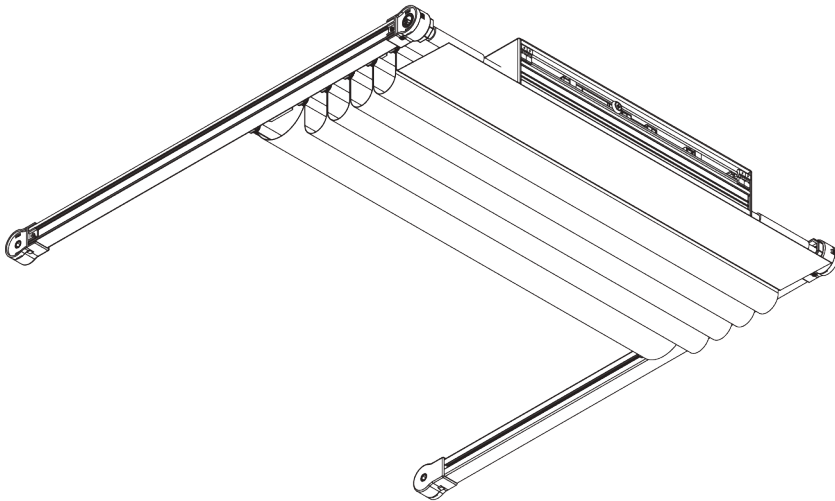
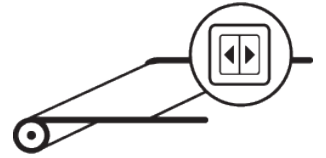

PRODUKTINFORMATIONEN

- **Bedienung:** Motor
- **Grösse:** S - L
- **Montage:** Aufmontage, Untermontage
- **Farben:** weiss RAL 9016 oder Aluminium farblos eloxiert, Sonderfarben möglich
- **Stoffe:** siehe Silent Gliss Stoffkollektion

Merkmale:

- Biegbar
- Auskragend
- Trapezform möglich
- Drei gekoppelte Systeme
- Vielfältige Steuerungsmöglichkeiten

SYSTEMSPEZIFIKATIONEN

A. MASSE / GEWICHT

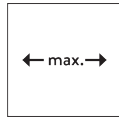

3 m
(plus 0,8 m pro Seite für
die Auskrägung)

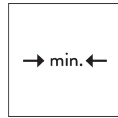

60 cm

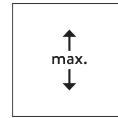

6 m



25 kg



18 m²

Max. System Grössen und Gewichte - Gerade Anlagen

SG 2195	A (m)		B (m)		kg _{max.}	m ² _{max.}	
	Type 1	Type 2/3	Type 1	Type 2/3	Type 1/2/3	Type 1/2/3	
		2.5	3	6	6	18	18
		2 / 2	2 / 2	6	6	18	24
		1.2 / 1.2 / 1.2	1.2 / 1.2 / 1.2	5	5	18	18
 $\triangle \text{max. } 45^\circ$		2.5	3	6	6	25	18
		2.5 / 2.5	2.5 / 2.5	6	6	25	30
		2 / 2 / 2	2 / 2 / 2	6	6	25	36
		2.5	3	6	6	25	18
		2.5 / 2.5	2.5 / 2.5	6	6	25	30
		2 / 2 / 2	2 / 2 / 2	6	6	25	36

Gebogene Anlagen

SG 2195	A (m)		B (m)		kg _{max}	m ²
	Type 1	Type 2/3	Type 1	Type 2/3	Type 1/2/3	Type 1/2/3
		2.5	2.5	6	6	18
	2 / 2	2 / 2	6	6	18	24
	1.2 / 1.2 / 1.2	1.2 / 1.2 / 1.2	6	6	18	21.6
	2.5	2.5	6	6	18	15
	1.5 / 1.5	1.5 / 1.5	5	5	18	15
	0.8 / 0.8 / 0.8	0.8 / 0.8 / 0.8	5	5	18	12
	2.5	2.5	4	4	15	10
	1.5 / 1.5	1.5 / 1.5	4	4	15	12
	0.8 / 0.8 / 0.8	0.8 / 0.8 / 0.8	3	3	15	7.2

B. PROFIL

Profil- und Biegeinformationen

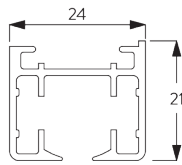

SG 2191
Profil

Radius:
✓ >25 cm

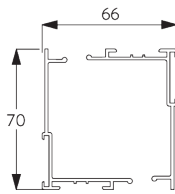

SG 2151
Profil

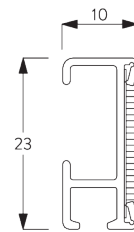

SG 2116
Velcroprofil

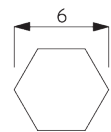

SG 2111
Welle



SG 2156
Welle

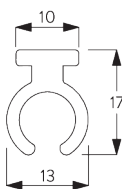

SG 2231
Profil



SG 2246
Profil

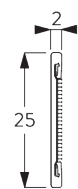

SG 2510
Velcroprofil

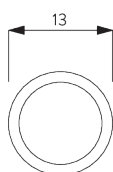

SG 2759
Profil

C. MASSAUFNAHME

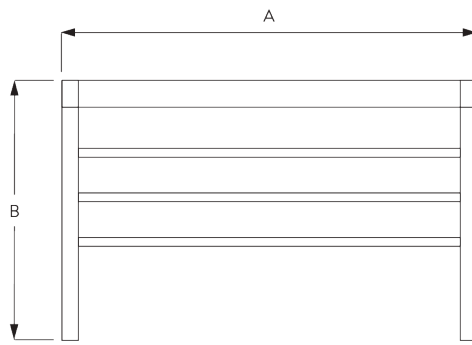

A: Systembreite
B: Systemhöhe

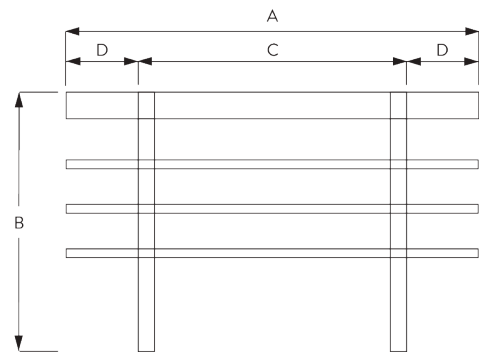

A: Systembreite
B: Systemhöhe
C: Grundanlage
D: Auskragung max. 80 cm

MONTAGE

A. MONTAGE- INFORMATIONEN

Detaillierte Montageinformationen siehe
Silent Gliss Website

Montagepunkte

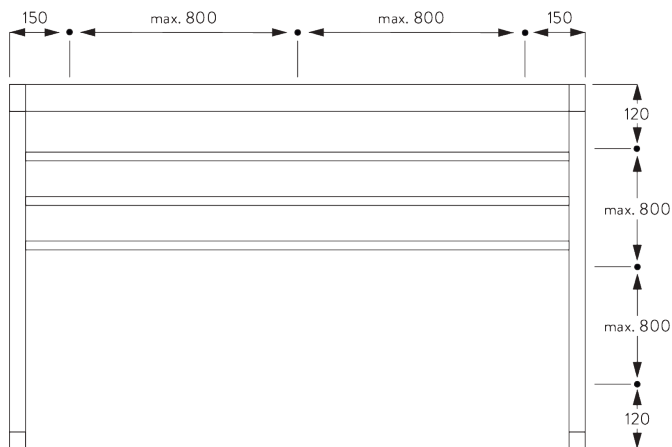

B. MONTAGE IN DEN RAHMEN

Spanner SG 3825

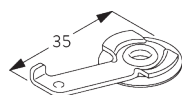
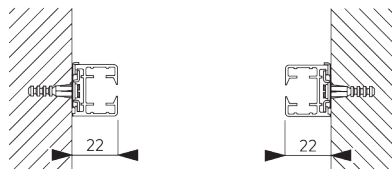

SG 3825
Spanner

**C. MONTAGE AUF
DEN RAHMEN**

**Träger SG 3181 /
SG 3182**

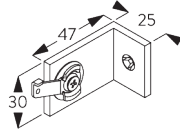
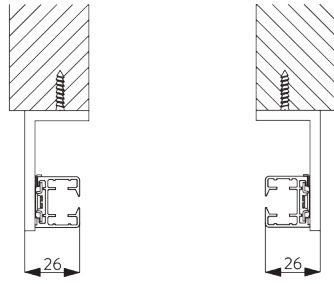

SG 3181

Träger mit 1 Spanner

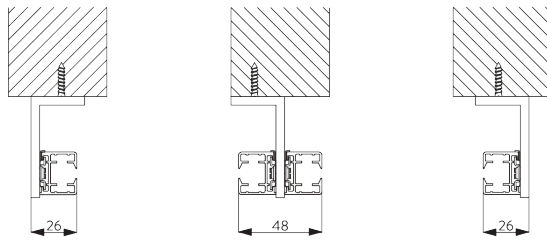

Gekoppelte Systeme

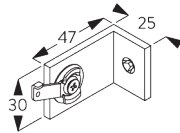

SG 3181

Träger mit 1 Spanner

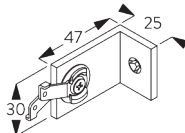

SG 3182

Träger mit 2 Spanner

SYSTEMOPTIONEN

**A. ZWEI ODER DREI
GEKOPPELTE
SYSTEME**

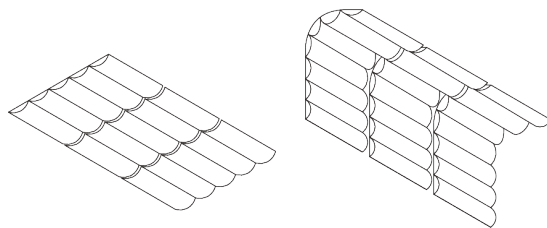

B. MONTAGE- OPTIONEN

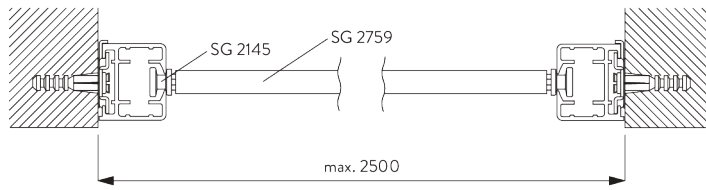

Typ 1

- SG 2145: Teleskop Gleiter
- SG 2759: Querstab

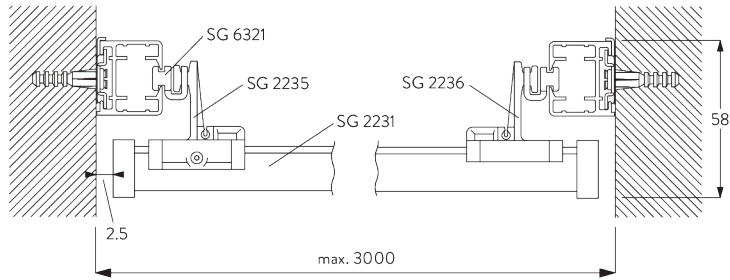

Typ 2 (Profile abgedeckt)

- SG 2231: Profil
- SG 2235: Gleiter mit Schraube
- SG 2236: Gleiter ohne Schraube
- SG 6321: Gleiter

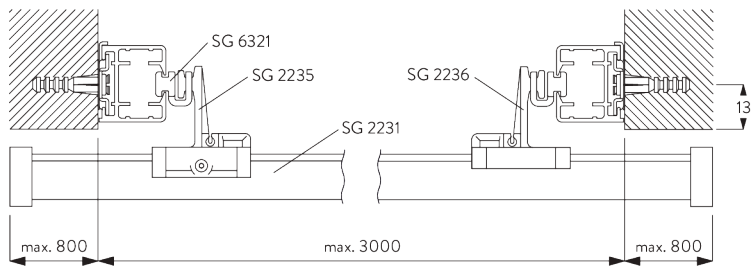

Typ 3 (Ausragende Version)

- SG 2231: Profil
- SG 2235: Gleiter mit Schraube
- SG 2236: Gleiter ohne Schraube
- SG 6321: Gleiter

C. STOFF FIXIERUNG

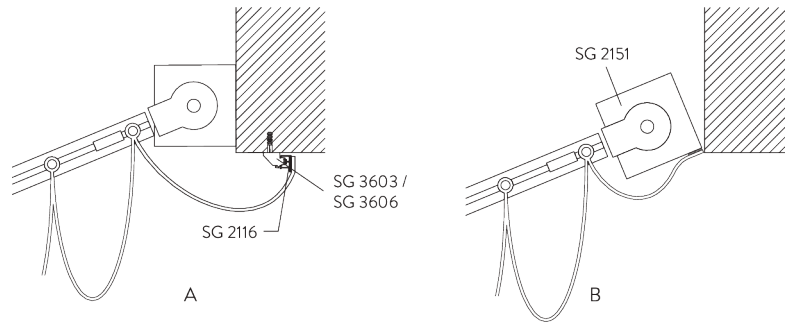

A: Fixieren des Stoffes mit Profil SG 2116 (Standard)

B: Fixieren des Stoffes direkt an Kopfprofilabdeckung

MOTOREN UND BEDIENUNGSARTEN

A. MOTOREN-MERKMALE

Motor	SG 2160
Motoreigenschaften	
Mechanischer Endstopp	•
Mechanischer Umdrehungszähler (Umdrehungszahl begrenzt)	•
Geräuschloser Stopp	•
IP Klasse	IP 44
Steuerungsmöglichkeiten	
Netzstrom	•
SG Control L (externer Funkempfänger erforderlich)	•
Geeignet für alle gängigen Hausautomationssysteme (mit passender Schnittstelle)	•

B. MOTOREN-SPEZIFIKATIONEN

Motor	Spannung	Stromstärke	Frequenz	Drehzahl
SG 2160	230 V AC	0.5 A	50 Hz	26 U/Min

Siehe Website für Schaltschema.

C. BEDIENUNGS-ARTEN

Siehe Katalog "Steuerungen" für mehr Details.

Wandschalter



Bedienbar mit drahtgebundenem Wandschalter.

SG Control L

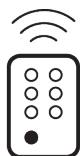

Verschiedene Funkfernsteuerungen erhältlich.
Ein externer Empfänger wird benötigt.



Silent Gliss Move App.





D. SCHALTSCHHEMA





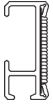
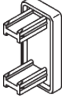
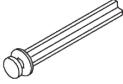

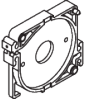
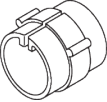
Siehe Silent Gliss Website.

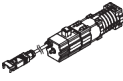
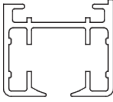
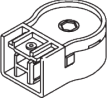
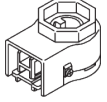
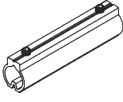
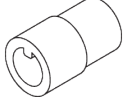

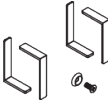
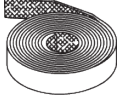
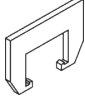
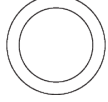
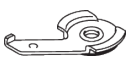
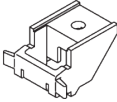

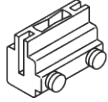
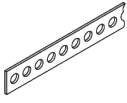

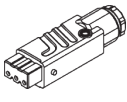
KOMPONENTEN

A. STANDARD KOMPONENTEN

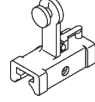
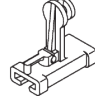
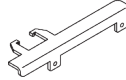
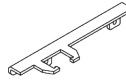
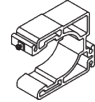
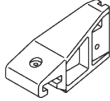
	SG 2116 Velcroprofil
	SG 2131 Enddeckel
	SG 2145 Gleiter
	SG 2151 Profil
	SG 2152 Lagerschale
	SG 2153 Rolle
	SG 2154 Deckel
	SG 2156 Welle
	SG 2160 Motor 230V AC, JA 06/26 soft
	SG 2191 Profil
	SG 2193 Umlenkung
	SG 2230 Antrieb
	SG 2242 Verbinder
	SG 2245 Verbinder

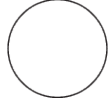
	SG 2247 Set Elero Motor 230 V
	SG 2539 Flauschband
	SG 2613 Verbinder
	SG 2759 Profil
	SG 3004 Spanner
	SG 3603 Träger
	SG 3825 Spanner
	SG 5005 Bandverbinder
	SG 5130 Antriebsband
	SG 6086 Verschlussfeder
	SG 6321 Gleiter
	SG 9917 Hirschmann Kupplung STAK 3 N

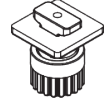
B. OPTIONALE KOMPONENTEN

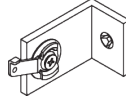
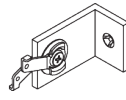
	SG 2231 Profil
	SG 2235 Quergleiter
	SG 2236 Quergleiter
	SG 2237 Überzugwagen rechts
	SG 2238 Überzugwagen links
	SG 2239 Führung
	SG 2241 Halter
	SG 2243 Enddeckel
	SG 2246 Profil
	SG 2249 Halter
	SG 2255 Bremsse
	SG 2510 Velcroprofil
	SG 3181 Träger mit 1 Spanner
	SG 3182 Träger mit 2 Spanner



SG 3606

Clip

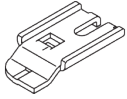

SG 3832

Träger

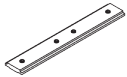

SG 5115

Profilverbinder

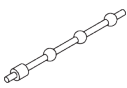

SG 6322

Abstandsschnur

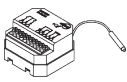

SG 9068

Funkempfänger Revio P

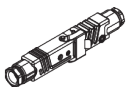

SG 9916

Hirschmann Kupplungsset

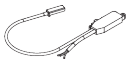

SG 9945

Funkempfänger 1 Kanal 230V

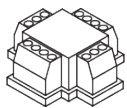

SG 9959

Trennrelais



SG 10300

Funkhandsender 1-Kanal



SG 10302

Funkhandsender 5+1-Kanal



SG 10303

Funkhandsender 10+2+1-Kanal



SG 10804

Funkhandsender 15+5+1 Kanal



SG 11480

Funkwandsender 1-Kanal



SG 11490

Funkwandsender 5+1-Kanal

